



Total Food-Service Solutions

Modular Cooking – Fryer

Gas Fryer Economic

GFE/40 RS



*Due to routine technical improvement, the photograph shown may not represent the latest design of the products.

AVAILABLE MODEL

1. GFE/40 RS

DESCRIPTION

Gas Fryer Economic is an excellent cooking appliance made of stainless steel and supported by 23 liters oil tank capacity. It consists of four gas burners with 21 kW power rate.

This appliance is suitable for deep- frying. The heat carried by four internal tubes at the bottom tank. Oil temperature is maintained by thermostat with maximum working temperature of 200°C. The burners are atmospheric and supplied by a mixture of liquid gas and air or natural gas and air. This appliance also equipped by Safety Thermocouple and Safety Thermostat to avoid overheat.

ITEM# : _____

MODEL# : _____

NAME : _____

SN : _____

MAIN FEATURE

- Maximum working temperature 200°C
- Gas Heating by Fire Chamber Pipe.
- Service maintenance can be done from the front door
- 23 Liters oil tank capacity
- 4 internal tubes for heating
- Atmospheric burners

CONSTRUCTION

- All exterior panels in 430 type of Stainless Steel.
- Tank is constructed of 1.5 mm of Stainless Steel.
- Side Panel is constructed of 0.8 mm of Stainless Steel.
- Adjustable ±25 mm Stainless Steel Leg.

INCLUDED ACCESSORIES

- Extra Nozzle (Main Burner & Open Burner).
- Basket Fryer.
- Crumb Screen.
- Fat Container.
- Extended Drain Pipe.

OPTIONAL ACCESSORIES

- N/A

The company reserves the right to make modifications to the products without prior notice. All information correct at time of printing. 2019.02.12



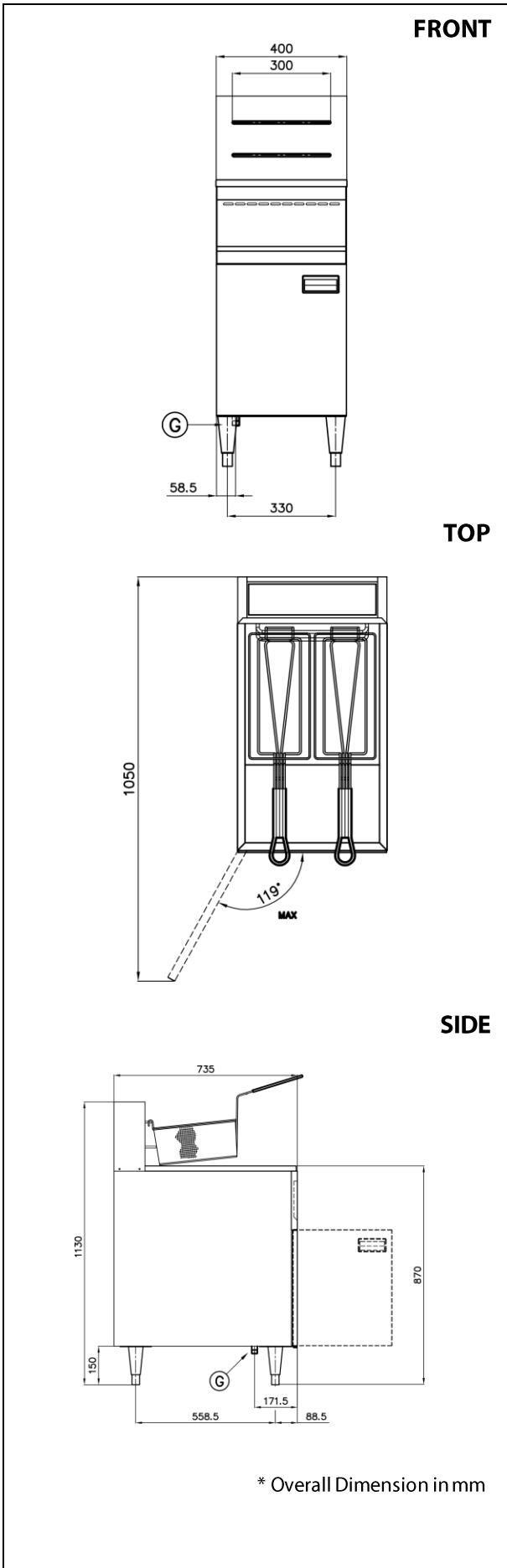

GAS

Gas Power	:	21 kW (18,060 kCal/h)
Gas Type Option	:	G30/G31, G20
Gas Connection	:	R 1/2"
Drain for Oil	:	1"
Natural Gas-Pressure	:	G20: 20 mbar
LPG Gas Pressure	:	28-30 mbar/ 37 mbar

KEY INFORMATION

Unit dimension (WxDxH)	:	400x735x870/1130 mm
Cooking Surface (WxD)	:	337 X 340 mm
Direct Heat Emission	:	1.89 kW
Latent Heat Emission	:	14.70 kW
Steam Emission	:	21.63 kg / h
Working Temperature	:	100°C-200°C
MAX Food Load	:	8 Kg
Tank Capacity	:	23 L
Number of Burners	:	4
Net weight	:	51 kg

PACKING DETAILS

Shipping width	:	470
Shipping depth	:	890
Shipping height	:	1310
Shipping volume	:	0.547 m ³
Gross weight	:	63 kg

The company reserves the right to make modifications to the products without prior notice. All information correct at time of printing. 2019.02.12